

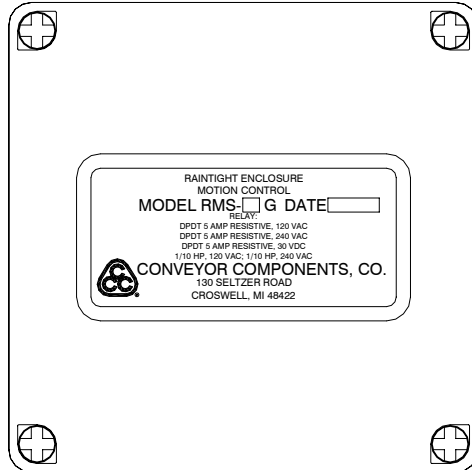

CONVEYOR COMPONENTS COMPANY

MODEL RMS INSTALLATION INSTRUCTIONS

RMS-1G; RMS-2G; RMS-3G



RMS-1; RMS-2; RMS-3

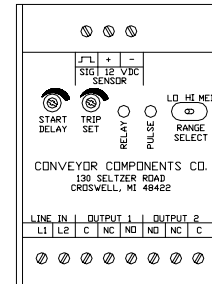

CONTENTS

	Page
A. Introduction	
1. Usage	2
2. How it operates	2
B. Specifications	
1. Sensor	2
2. Control	3
C. Installation	
1. Location and mounting	4
2. Wiring	4
3. Signal set point	5
4. Time delay setting	6
D. Trouble shooting	
1. Problems and solutions	7
2. Factory assistance	8
E. Warranty and parts	
1. Warranty	8
2. Electronics replacement	8

A. INTRODUCTION

1. Usage

The model RMS is a compact motion sensing control. It is available in a DIN version for panel mounting in an enclosure, or a NEMA 4X version. It will produce an output relay closure at a predetermined speed which may be either overspeed, underspeed, or zero speed. A compact enclosure combined with solid state electronics, make this one of the most advanced motion detectors available. The model RMS protects all valuable rotating equipment including belt conveyors, bucket elevators, rotary feeders, or screw conveyors. It uses a remote mounted inductive sensor to monitor rotation speed in harsh environments.

2. How it operates

The model RMS senses motion by means of pulses received from a remote inductive sensor. The sensor generates measurable pulses by a metal target, which rotates past it. These pulses are converted to a digital electronic signal. Solid state circuitry then analyzes the digital signal and activates or de-activates the output relay at the pre-set speed.

Field adjustment of the signal set point is easily accomplished by means of an adjustment screw on the electronics. For underspeed sensing, the signal point is set below the normal operating speed of the unit. The output relay will then de-energize if the speed drops below the signal point. For overspeed sensing, the pick-up point is set above the normal operating speed. The output relay will energize if the speed exceeds the pick up point. Zero speed sensing can be accomplished by turning the adjustment screw to its minimum setting. The output relay will then de-energize when the shaft speed of the unit approaches zero.

B. SPECIFICATIONS

Table 1: Motion Sensor Specifications				
Part number	RMS-8S	RMS-12S	RMS-18S	RMS-30S
Sensor type	2 wire DC	2 wire DC	2 wire DC	2 wire DC
Body diameter	8mm (0.31 in)	12mm (0.47 in)	18mm (0.71 in)	30mm (1.18 in)
Body length	50mm (1.96 in)	71mm (2.80 in)	80mm (3.15 in)	81mm (3.19 in)
Thread size	M8	M12	M18	M30
Cable length	2m (6.6 ft)	2m (6.6 ft)	2m (6.6 ft)	2m (6.6 ft)
Sensing range	1.0mm (0.04)	2.0mm (0.08)	5.0mm (0.20)	10mm (0.30)
Maximum pulse rate	2 KHz	1.5 KHz	1.0 KHz	0.6 KHz
Maximum voltage	30 VDC	30 VDC	30 VDC	30 VDC
Maximum current	100 MA	100 MA	100 MA	100 MA

Table 2: RMS Control Unit Specifications		
Model	Input	Features
RMS-1	105-135 VAC, 50/60 Hz	Electronics and NEMA 1 DIN enclosure
RMS-1G	105-135 VAC, 50/60 Hz	Electronics and NEMA 4X Enclosure
RMS-2	210-250 VAC, 50/60 Hz	Electronics and NEMA 1 DIN enclosure
RMS-2G	210-250 VAC, 50/60 Hz	Electronics and NEMA 4X Enclosure
RMS-3	24 AC/DC	Electronics and NEMA 1 DIN enclosure
RMS-3G	24 AC/DC	Electronics and NEMA 4X Enclosure
Output		DPDT relay to 5 Amp. Resistive at 120 volts A.C.
		DPDT relay to 5 Amp. Resistive at 240 volts A.C.
		DPDT relay to 5 Amp. Resistive at 30 volts D.C.
		1/10 Horse Power at 120 volts A.C.
		1/10 Horse Power at 240 volts A.C.
Operating Temperature Range		-50 deg. F to +150 deg. F
Repeatability		+2% maximum at constant voltage and temperature
Power consumption		3 Watts
Pick up point		3 Input Ranges at which relay will energize
LOW		2 to 120 PPM
MEDIUM		20 to 1200 PPM
HIGH		200 to 12000 PPM
Signal point		Speed at which relay will de-energize. Recommended to be 15-20% lower than pick up point. This will eliminate nuisance shutdowns.
Start up delay		Adjustable up to 45 seconds
Enclosure		Plastic
Weight		1 lb.
Size:		
RMS-1, RMS-2, RMS-3		3" high x 2.25" wide x 4.25" long [76 x 57 x 108 mm]
RMS-1G, RMS-2G, RMS-3G		2.95" high x 4.92" wide x 4.92" long [75 x 125 x 125 mm]



C. INSTALLATION

1. Location and mounting (See Figure 3 for examples.)

The model RMS motion switch can be mounted in a panel on a DIN rail (See figure 2) or by using two screws. The model RMS-G is equipped with a NEMA 4X enclosure, and can be mounted using screws.

For normal sensor installations, use 1/4" diameter machine bolts with lock washers through the two mounting holes in the base of the mounting bracket. (Mounting bolts and lock washers are not furnished with the switch.) The sensor should be mounted at a right angle to the object to be sensed at a distance as indicated in Table 1.

2. Wiring

Wire input power from source to terminals L1 and L2. The output of the model RMS is a DP/DT relay. There are two sets of output contacts. Each set includes normally open, normally closed, and common. As a result, the unit can be used to control two separate circuits such as a motor starter and a signal light.

Figure 1: Wiring Layout Models RMS-1G, RMS-2G, RMS-3G; These models are supplied with a time delay / set point adjusting tool.

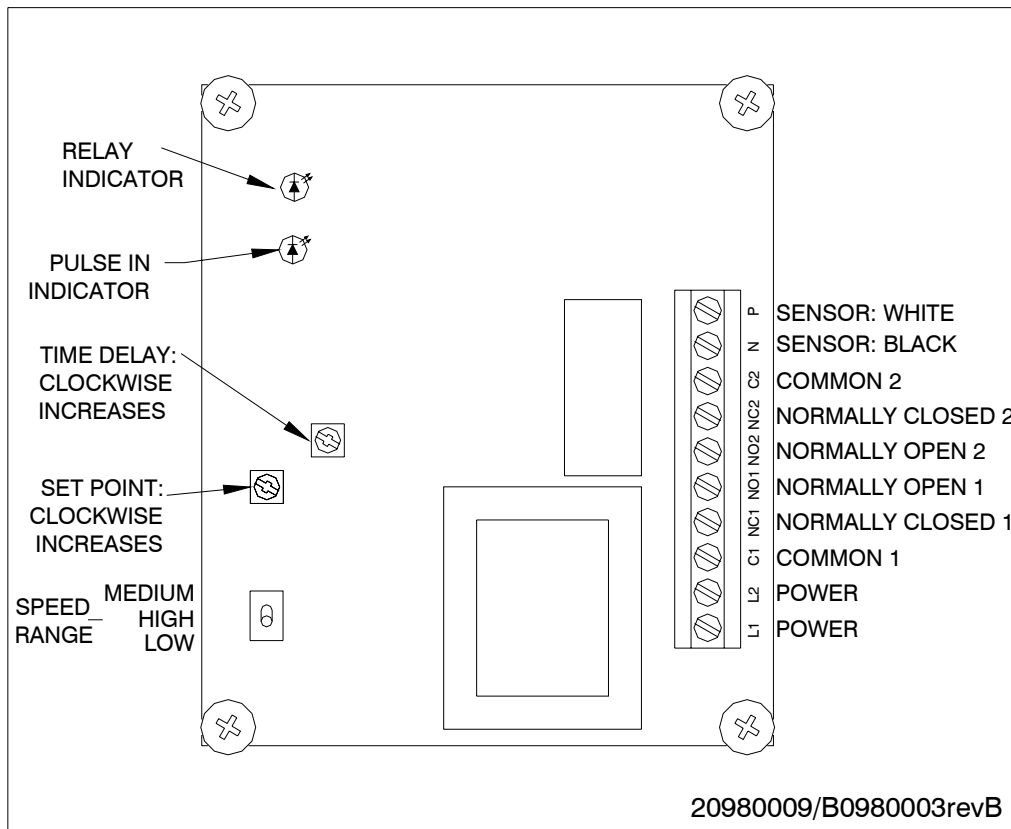
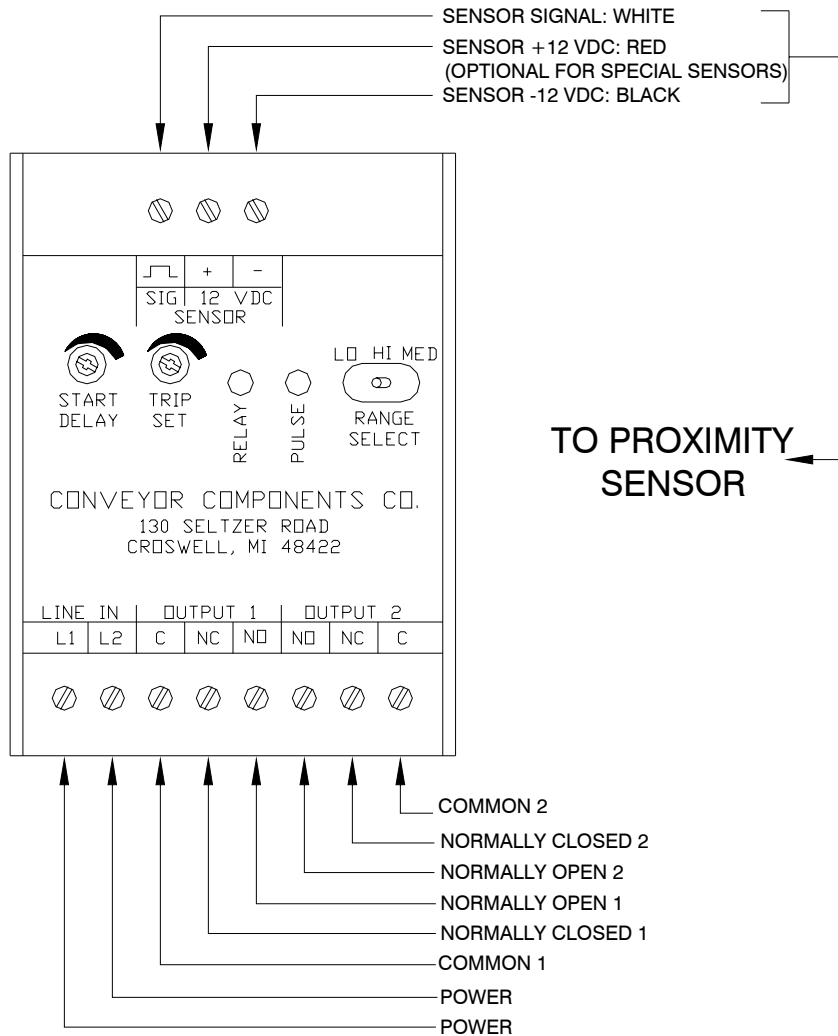

Figure 2: Wiring Layout Models RMS-1, RMS-2, RMS-3



3. Signal set point

FOR USE AS AN UNDERSPEED SWITCH:

1. Select the speed range required by changing the switch to LOW for 2 to 120 ppm., MEDIUM for 20 to 1200 ppm., and HIGH for 200 to 12000 ppm.
2. Turn the setpoint potentiometer to the counterclockwise stop. With signal present from the sensor and at normal operating speed, the yellow pulse indicator L.E.D. should blink. The green pulse indicator L.E.D. should turn on indicating that the output relay is energized.
3. Slowly turn the setpoint adjustment screw clockwise until the output relay de-energizes (a "click" will occur at this point). The green L.E.D. will turn off.
4. Back up until the output relay energizes. Thus, when speed drops below the setpoint, the green L.E.D. should turn off indicating that the output relay is de-energized.

5. If the normal operating speed exceeds 120 P.P.M. for the LOW or 1200 P.P.M. for the MEDIUM or 12000 P.P.M. for the HIGH, the unit should be adjusted as follows. Turn the setpoint adjustment screw clockwise until it reaches the stop. When the speed drops below 120 P.P.M. for the LOW or 1200 P.P.M. for the MEDIUM or 12000 P.P.M. for the HIGH, the relay will energize.
6. Note: Typically, the motor contactor is wired in series with one of the N.O. output contacts; and an alarm is wired with one of the N.C. output contacts.

FOR USE AS AN OVERSPEED SWITCH:

1. Select the speed range required by changing the switch to LOW for 2 to 120 ppm., MEDIUM for 20 to 1200 ppm., and HIGH for 200 to 12000 ppm.
2. Turn the setpoint potentiometer to the counterclockwise stop. With motion present on the input shaft and at normal operating R.P.M., the yellow pulse indicator L.E.D. should blink. The green relay indicator L.E.D. should turn on indicating that the output relay is energized.
3. Slowly turn the setpoint adjustment screw clockwise until the output relay de-energizes and the green L.E.D. turns off. (a "click" will occur at this point). With the potentiometer on that setting, if the speed increases the output relay will energize.
4. Note: Typically, the motor contactor is wired in series with one of the N.O. output contacts; and an alarm is wired with one of the N.C. output contacts.

FOR USE AS A ZERO SPEED SWITCH:

1. Select the LOW speed range by changing the switch to LOW for 2 to 120 ppm.
 2. Turn the setpoint potentiometer to the counterclockwise stop. This will give a setpoint setting of 2 P.P.M. Thus, when the speed drops below 2 P.P.M., the output relay will de-energize.
 3. Note: Wiring should be the same as for underspeed applications.
4. Time delay setting
The model RMS motion sensing control has a start up delay that is adjustable up to 45 seconds. This setting should be set, depending on the application and the length of time it takes for the conveyor to reach it's normal operating speed. This time delay takes effect upon power-up of the model RMS after shutdown. AC power to the model RMS must be interrupted for timer to be reset. This delay only affects start up, avoiding nuisance start up alarms.

D. TROUBLE SHOOTING

1. Problems and solutions

Problem:

No pulses from yellow pulse indicator LED.

Solution:

Check power supply.
Make sure there is a signal from the sensor.
Check to see if the LED in the sensor is blinking.

Problem:

Relay is not energized or de-energized when expected. (i.e. green relay indicator LED not on or off when expected)

Solution:

Check power supply.
Make sure there is a signal from the sensor.
Check for proper set point.
Check for proper speed setting. (Low, Medium, or High)

Problem:

Alarm sounds when equipment is started.

Solution:

Check start up delay setting.
Check for proper connections between alarm and relay.
AC power must be interrupted for alarm to reset.

Problem:

Alarm does not go off when expected.

Solution:

Check power supply.
Check for proper connections between alarm and relay.

Problem:

Equipment is not shut off when expected.

Solution:

Check power supply.
Check for proper connections between control circuit and relay.

2. Factory assistance

If assistance is needed to locate difficulties with a unit, or you would like information about alternate control devices, please call the factory at 1-800-233-3233.

To help solve a problem quickly, please have as much of the following information as possible when you make your call:

- *Model number
- *Date purchased
- *Brief application information
- *Brief description of the problem

EQUIPMENT SHIPPED BACK TO THE FACTORY WITHOUT PROPER AUTHORIZATION WILL BE REFUSED AND RETURNED AT THE SHIPPER'S EXPENSE.

E. WARRANTY AND PARTS

1. Warranty

Refer to Manufacture's General Terms and Conditions of Sale for warranty information.

2. Electronics Replacement

Please contact our sales department for replacement parts and availability.

Figure3: Mounting Examples.

